

A2D210-AA02-11

# AC axial fan

straight blades (A series)



## ebm-papst Mulfingen GmbH & Co. KG

Bachmühle 2 · D-74673 Mulfingen

Phone +49 7938 81-0

Fax +49 7938 81-110

info1@de.ebmpapst.com

www.ebmpapst.com

Limited partnership · Headquarters Mulfingen

Amtsgericht (court of registration) Stuttgart · HRA 590344

General partner Elektrobau Mulfingen GmbH · Headquarters Mulfingen

Amtsgericht (court of registration) Stuttgart · HRB 590142

## Nominal data

Type	A2D210-AA02-11	
Motor	M2D068-CF	
Phase		3~
Nominal voltage	VAC	400
Wiring		Y
Frequency	Hz	50
Method of obtaining data		fa
Valid for approval/standard		CE
Speed (rpm)	min <sup>-1</sup>	2700
Power consumption	W	80
Current draw	A	0.14
Max. ambient temperature	°C	-

ml = Max. load · me = Max. efficiency · fa = Free air · cs = Customer specification · ce = Customer equipment  
Subject to change



# AC axial fan

straight blades (A series)

## Technical description

<b>Weight</b>	1.6 kg
<b>Fan size</b>	210 mm
<b>Rotor surface</b>	Unpainted
<b>Impeller material</b>	Sheet steel, galvanized
<b>Number of blades</b>	5
<b>Airflow direction</b>	"V"
<b>Direction of rotation</b>	Counterclockwise, viewed toward rotor
<b>Degree of protection</b>	IP44; installation- and position-dependent as per EN 60034-5
<b>Insulation class</b>	"F"
<b>Moisture (F) / Environmental (H) protection class</b>	F1-1
<b>Max. permitted ambient temp. for motor (transport/storage)</b>	+ 80 °C
<b>Min. permitted ambient temp. for motor (transport/storage)</b>	- 40 °C
<b>Installation position</b>	Shaft horizontal or rotor on bottom; rotor on top on request
<b>Condensation drainage holes</b>	On rotor side
<b>Mode</b>	S1
<b>Motor bearing</b>	Ball bearing
<b>Touch current according to IEC 60990 (measuring circuit Fig. 4, TN system)</b>	< 0.75 mA
<b>Motor protection</b>	Thermal overload protector (TOP) with basic insulation
<b>With cable</b>	Lateral
<b>Protection class</b>	I (with customer connection of protective earth)
<b>Conformity with standards</b>	EN 60335-1; CE



## Product drawing

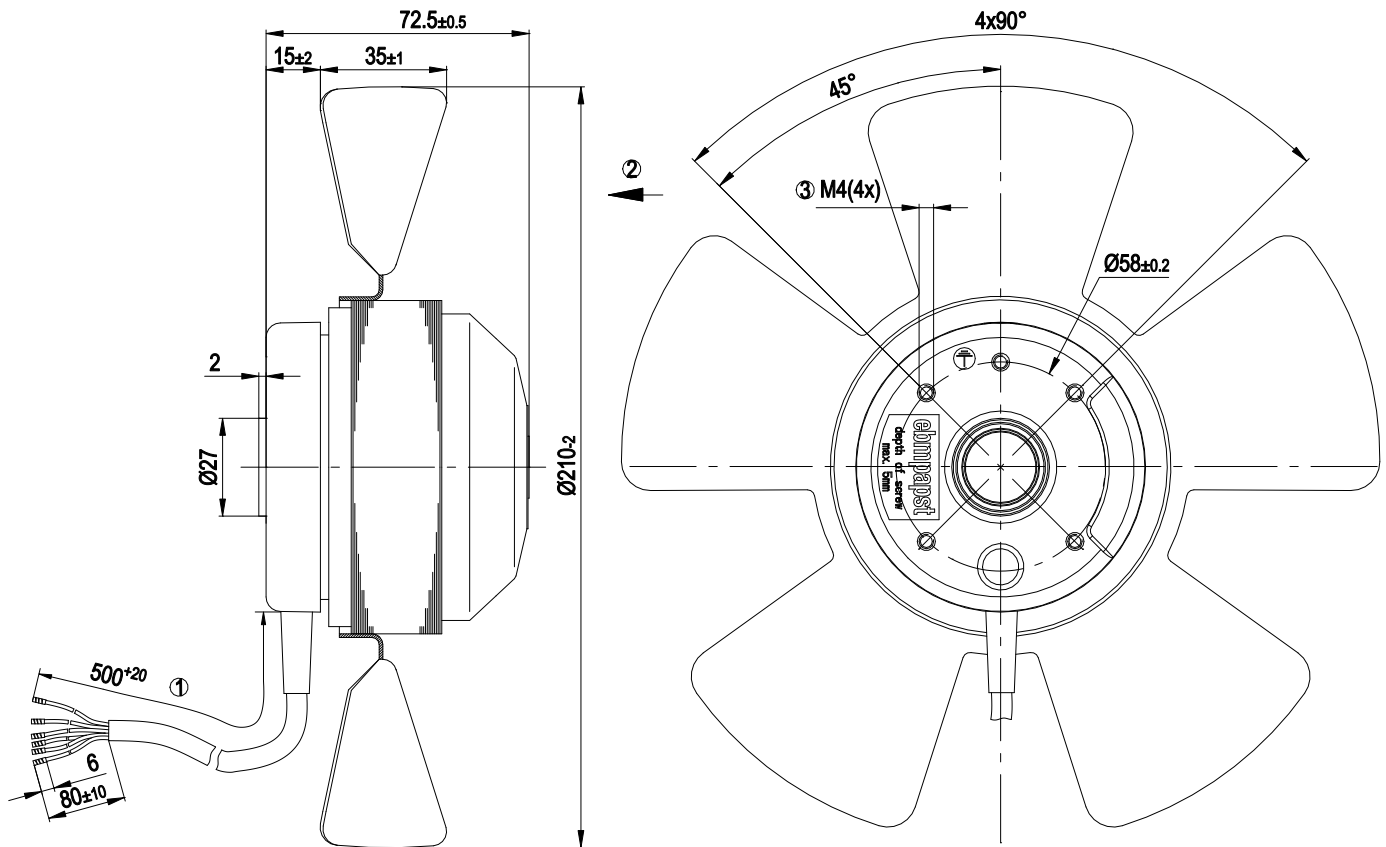

1	Cable halogen-silicone-free 6X 0.5 mm <sup>2</sup> , 6 x crimped splices
2	Direction of air flow "V"
3	Max. clearance for screw 5 mm

# AC axial fan

straight blades (A series)

## Connection diagram

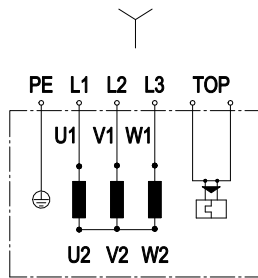

Note: Change of rotation direction by reversing two phases

Y	Star connection	L1	= U1 = black	L2	= V1 = blue
L3	= W1 = brown	PE	green/yellow	TOP	2x gray

## Curves: Air performance 50 Hz

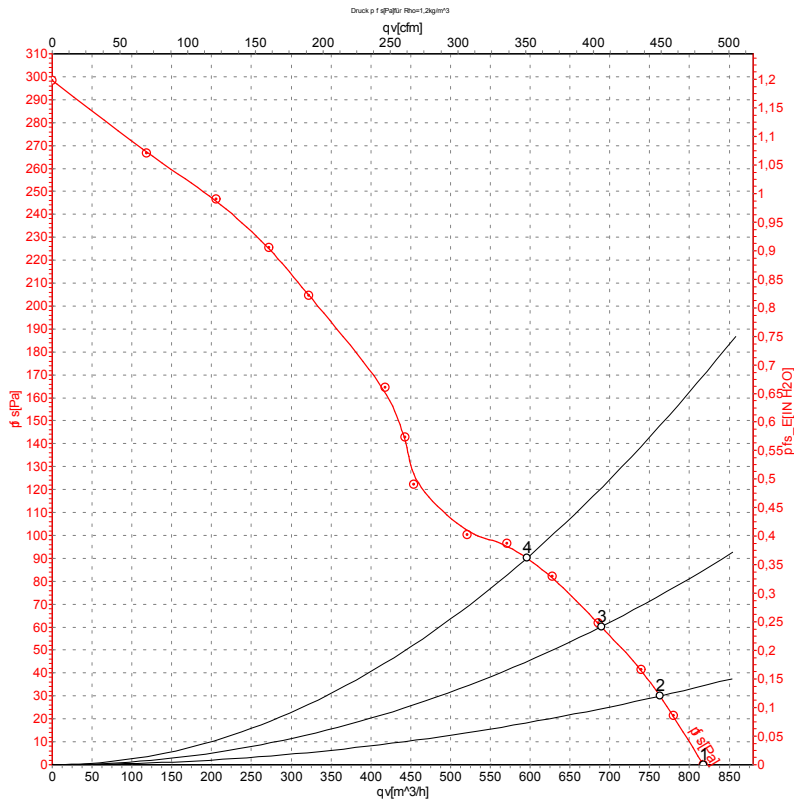

Measurement: LU-20133-1

Air performance measured according to ISO 5801 installation category A. For detailed information on the measurement setup, contact ebm-papst. Intake sound level: Sound power level according to ISO 13347 / sound pressure level measured at 1 m distance from fan axis. The values given are valid under the specified measuring conditions and may vary due to conditions of installation. For deviations from the standard configuration, the parameters have to be checked on the installed unit.

## Measured values

	U	f	n	P <sub>e</sub>	I	qv	p <sub>fs</sub>	qv	p <sub>fs</sub>
	V	Hz	min <sup>-1</sup>	W	A	m <sup>3</sup> /h	Pa	CFM	inH2O
1	400	50	2750	60	0.15	820	0	480	0.00
2	400	50	2730	63	0.15	765	30	450	0.12
3	400	50	2715	65	0.15	690	60	405	0.24
4	400	50	2705	67	0.15	595	90	350	0.36

U = Power supply · f = Frequency · n = Speed (rpm) · P<sub>e</sub> = Power consumption · I = Current draw · qv = Air flow · p<sub>fs</sub> = Pressure increase



## Curves: Air performance 60 Hz

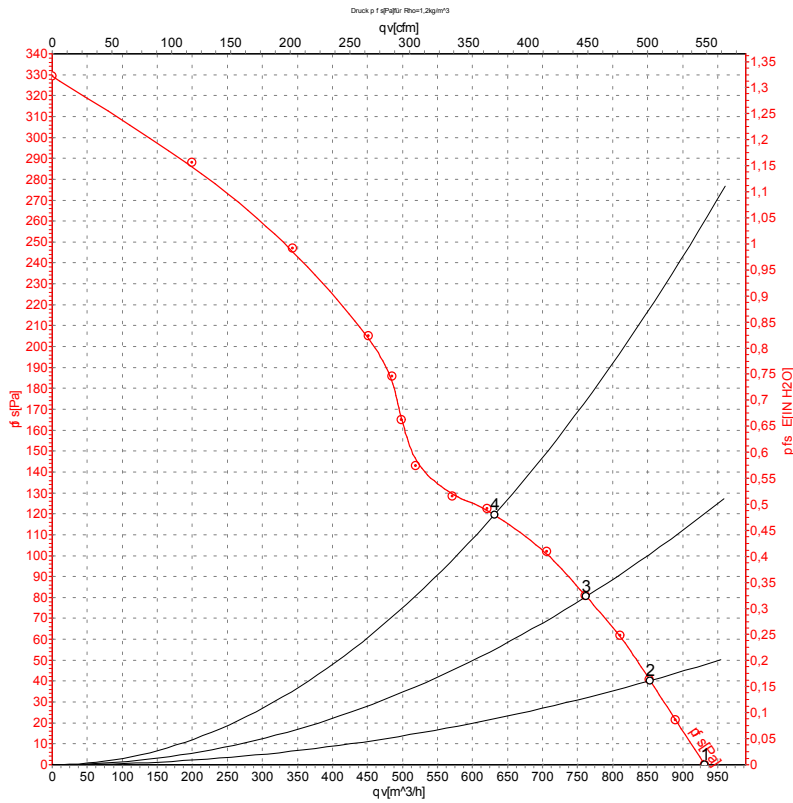

Measurement: LU-20134-1

Air performance measured according to ISO 5801 installation category A. For detailed information on the measurement setup, contact ebm-papst. Intake sound level: Sound power level according to ISO 13347 / sound pressure level measured at 1 m distance from fan axis. The values given are valid under the specified measuring conditions and may vary due to conditions of installation. For deviations from the standard configuration, the parameters have to be checked on the installed unit.

## Measured values

	U	f	n	P <sub>e</sub>	I	qv	p <sub>fs</sub>	qv	p <sub>fs</sub>
	V	Hz	min <sup>-1</sup>	W	A	m <sup>3</sup> /h	Pa	CFM	inH <sub>2</sub> O
1	400	60	3100	81	0.15	930	0	550	0.00
2	400	60	3070	85	0.15	855	40	505	0.16
3	400	60	3040	88	0.15	760	80	450	0.32
4	400	60	3030	89	0.15	630	120	370	0.48

U = Power supply · f = Frequency · n = Speed (rpm) · P<sub>e</sub> = Power consumption · I = Current draw · qv = Air flow · p<sub>fs</sub> = Pressure increase

